



nickelodeon

SpongeBob  
SQUAREPANTS

3817



1

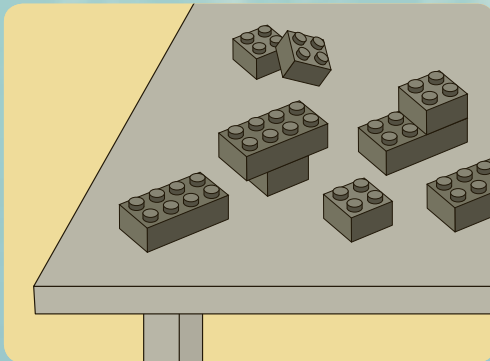
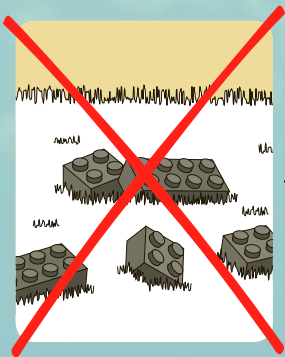

2



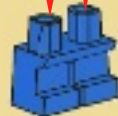
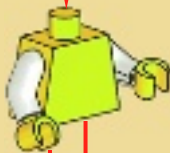



1

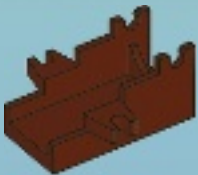

2



3

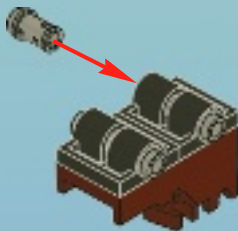

4



5

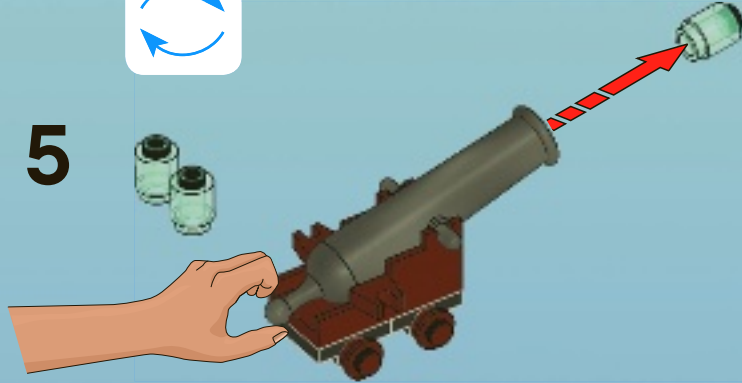



1



2



3

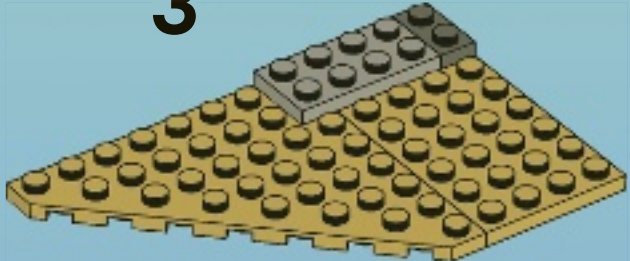

4

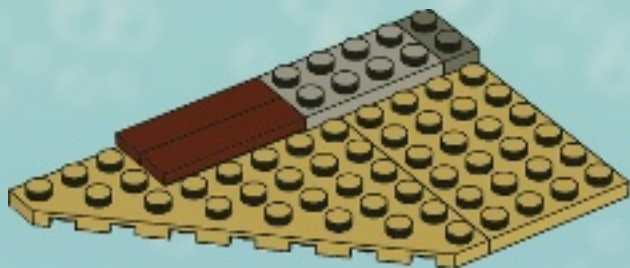

5

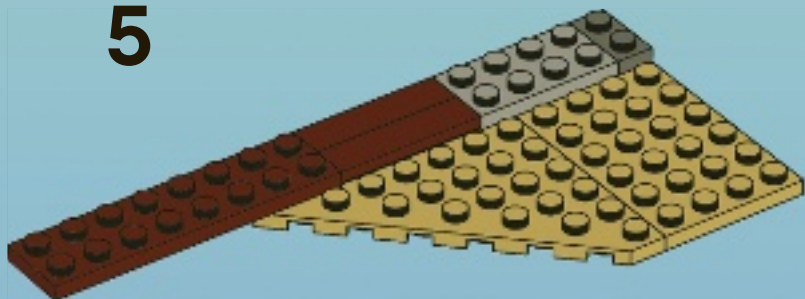





6

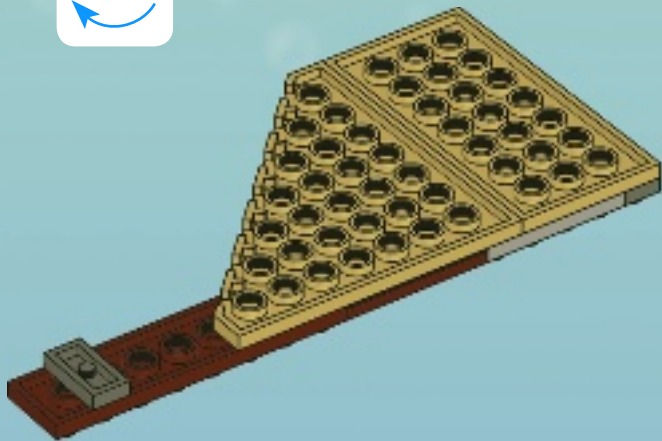



7

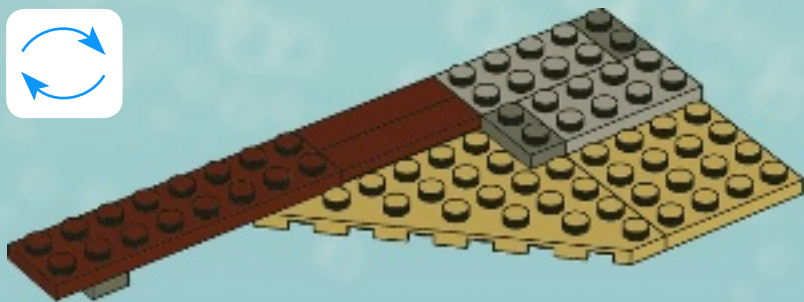

8

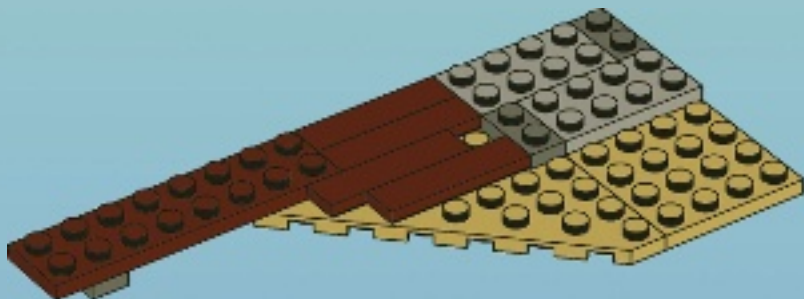

9

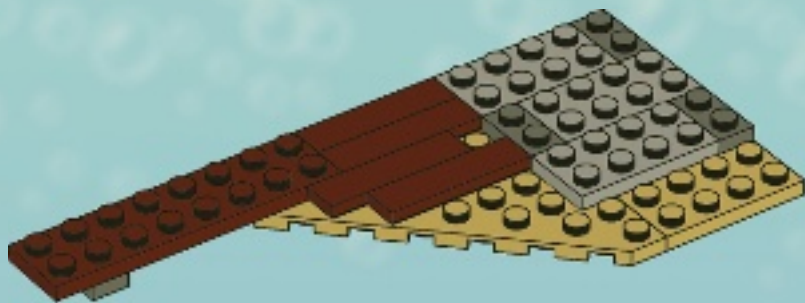

10

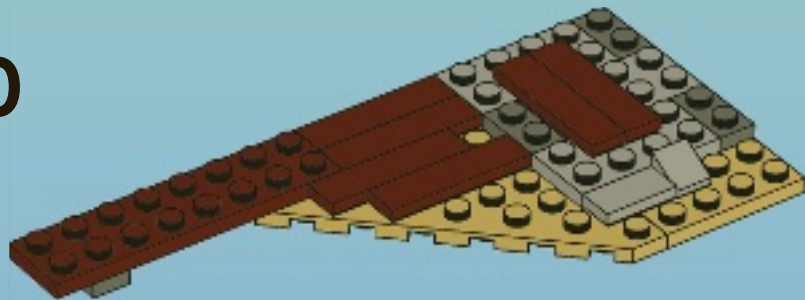

11

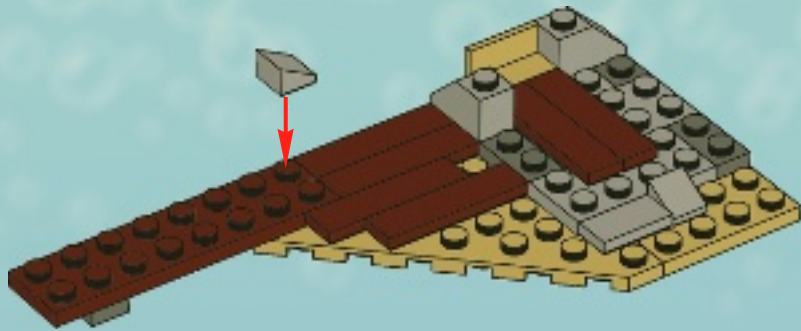

12

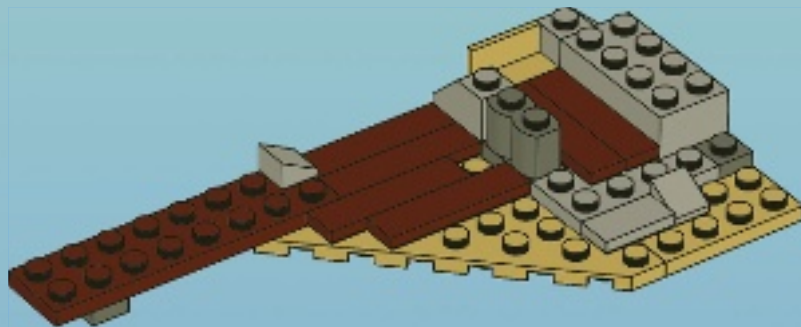

13

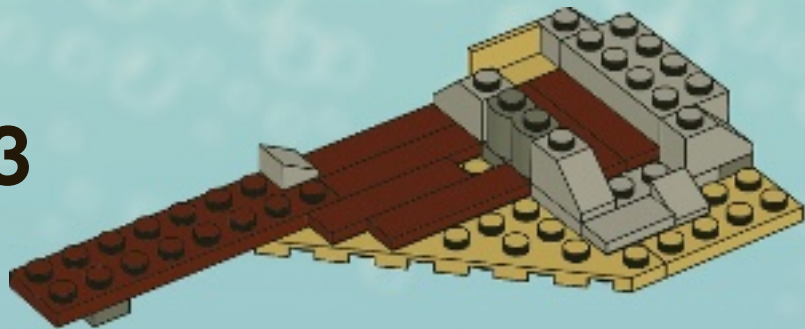

14

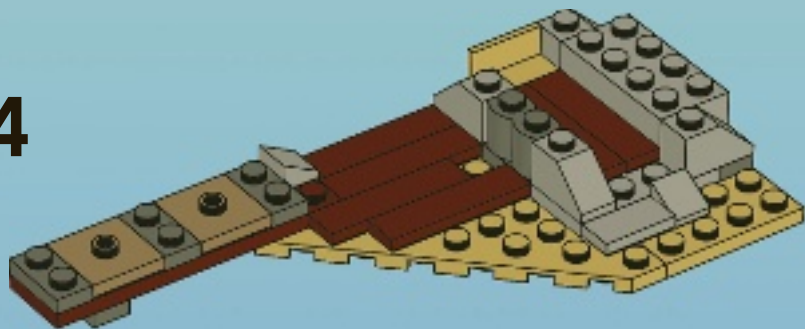

1



2



15

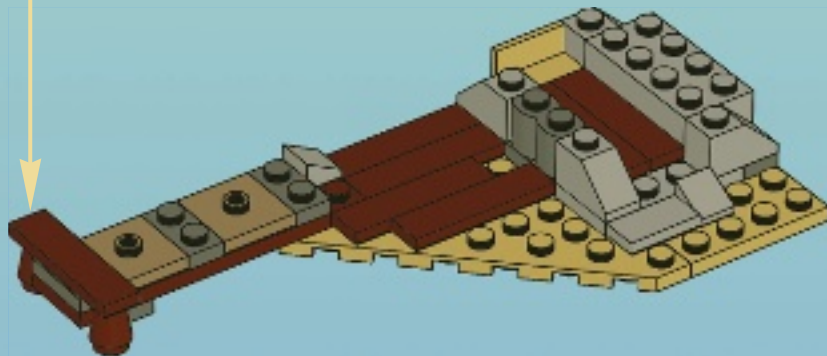

16

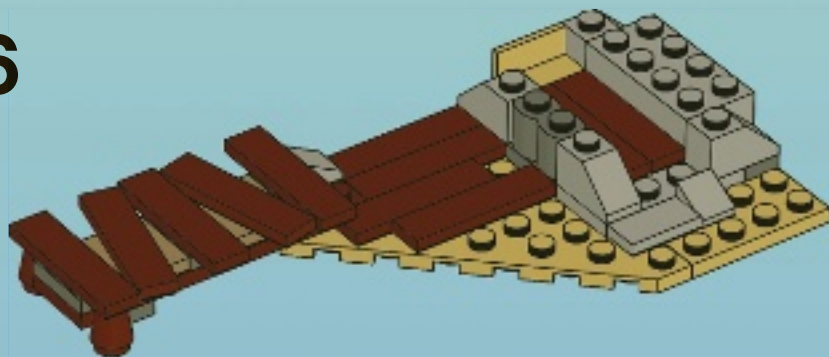

17

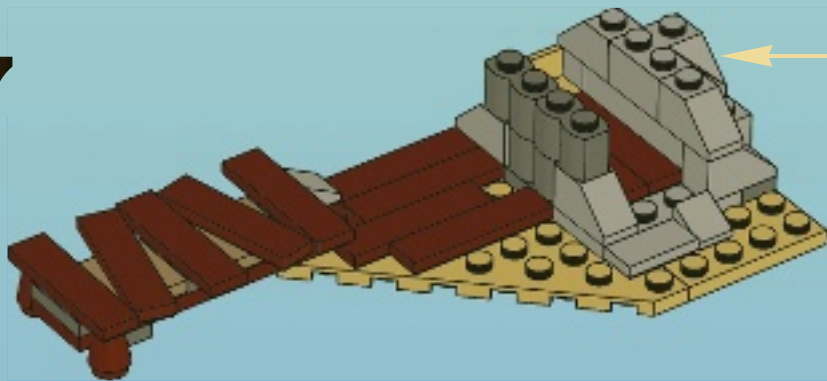



18

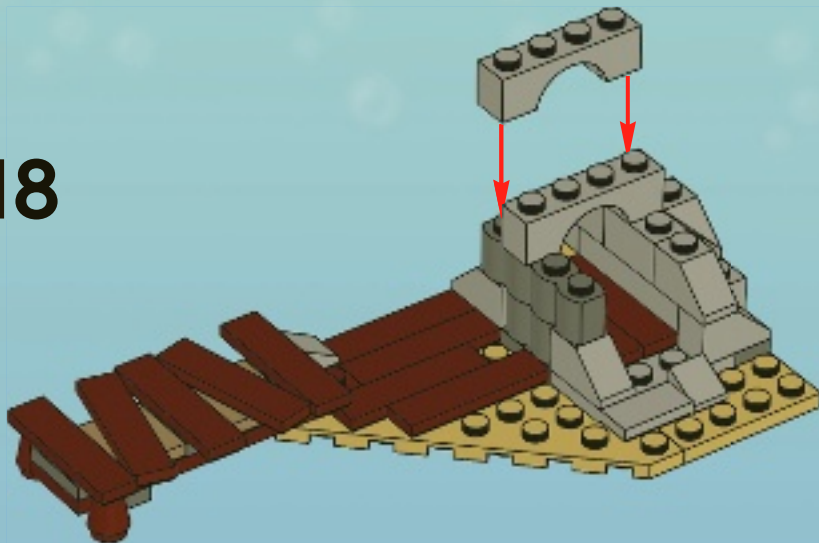

19

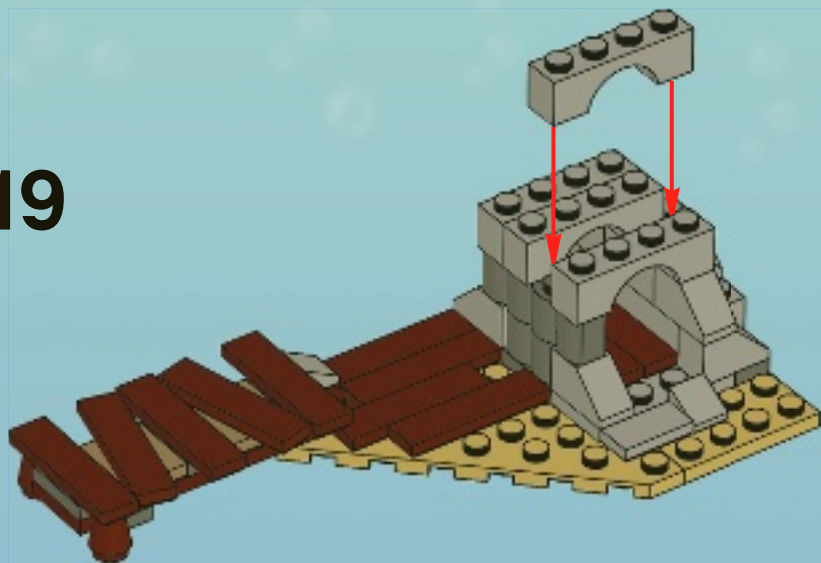

20

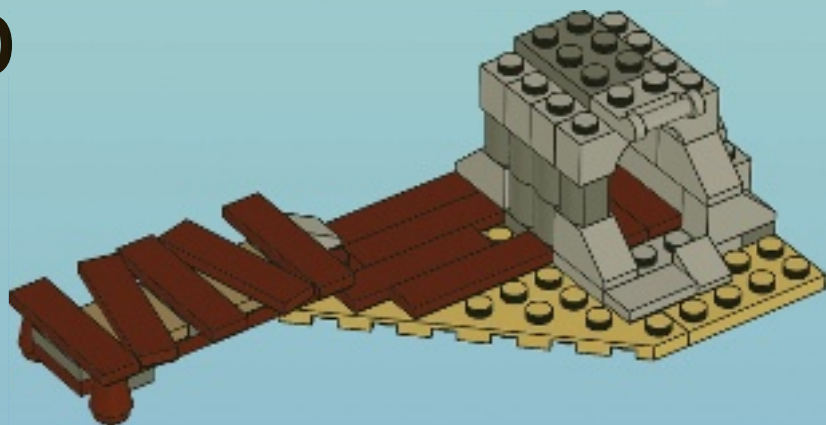

21

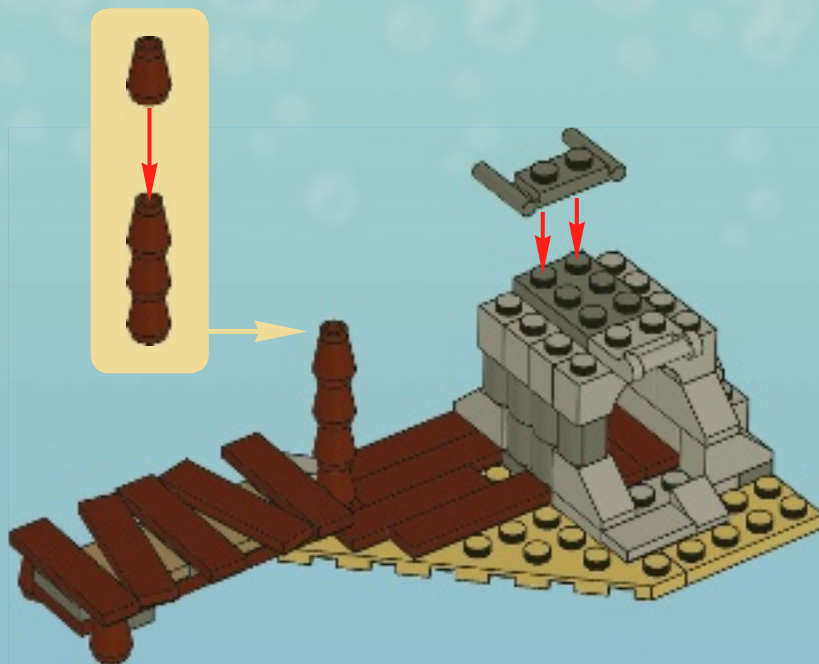

22

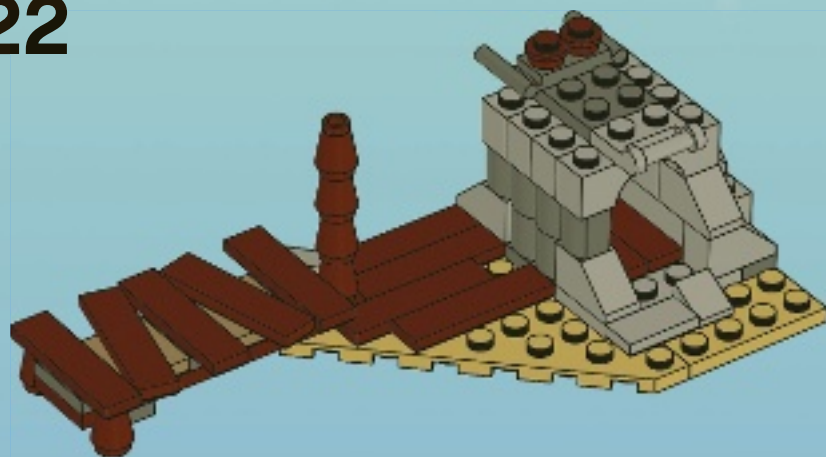

23

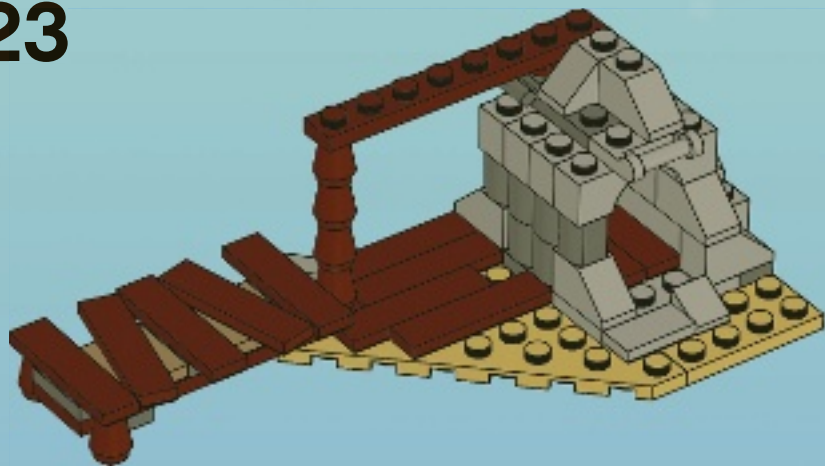

24

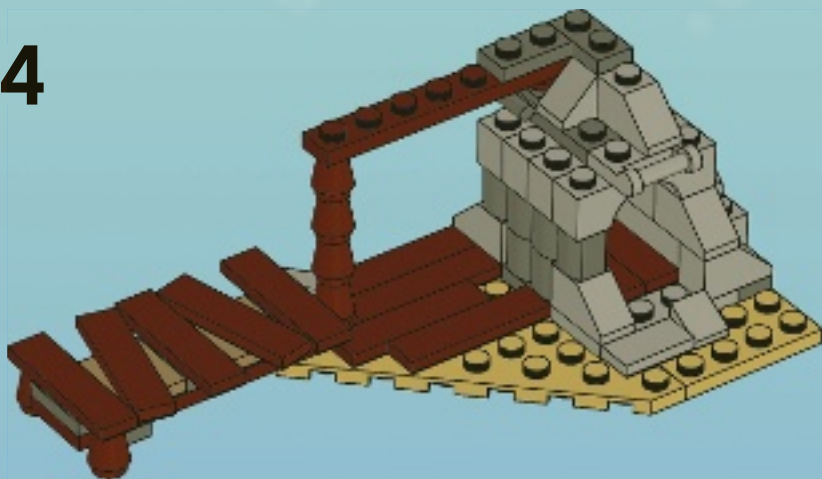





25

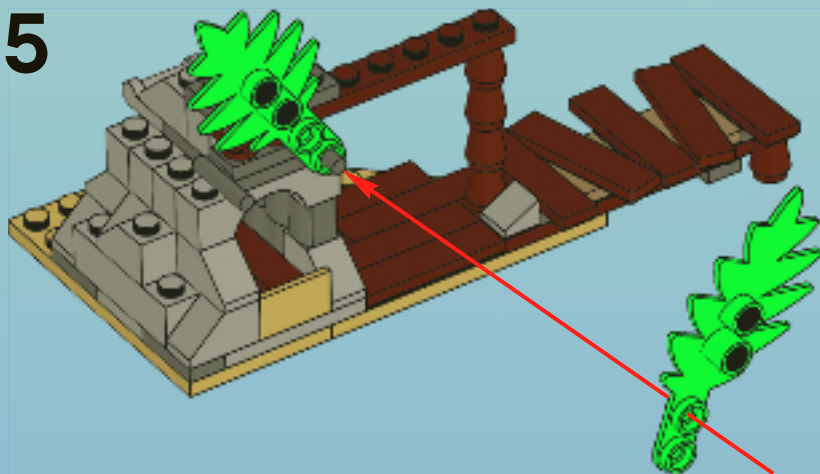



26



27



28





1

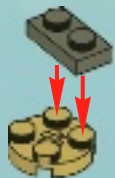

2



3



4



29

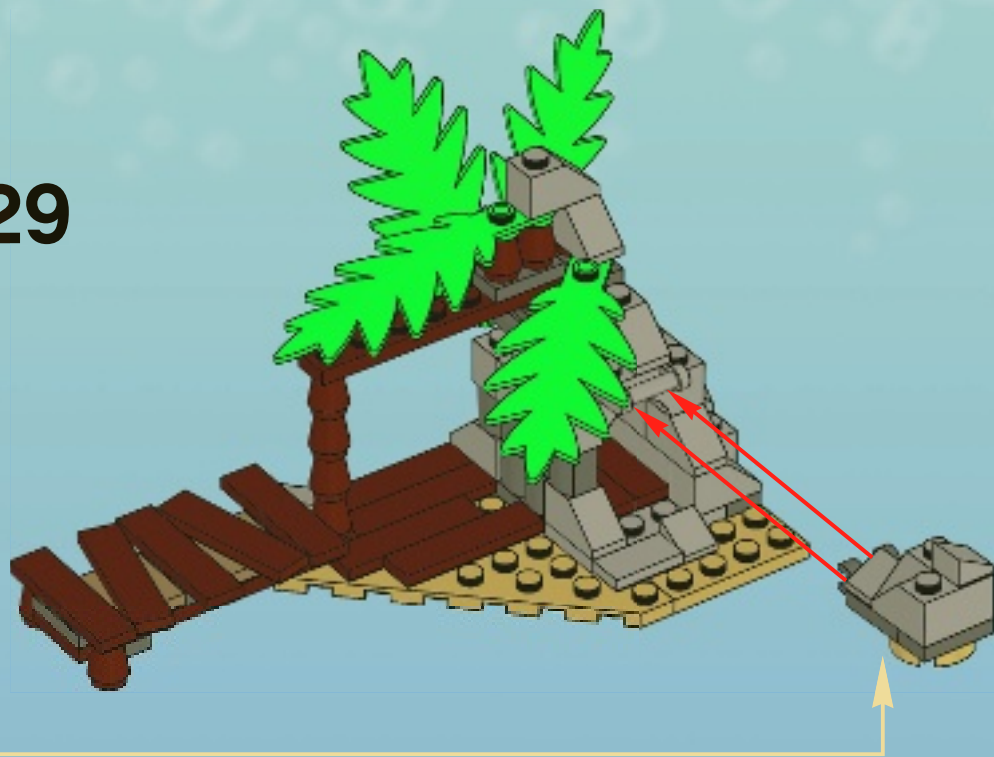

30

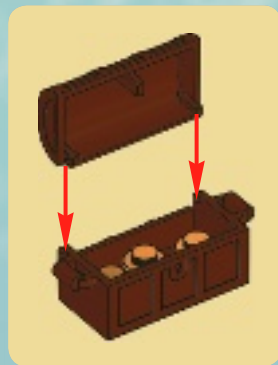



31





1



2



**3**

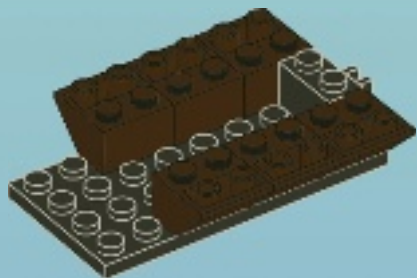

**4**

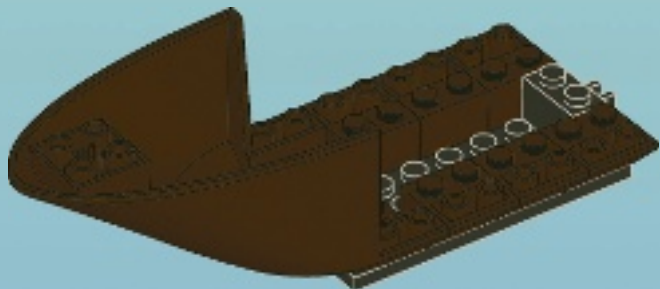

5

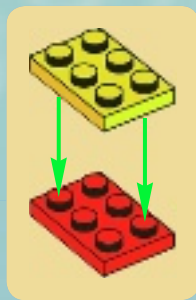
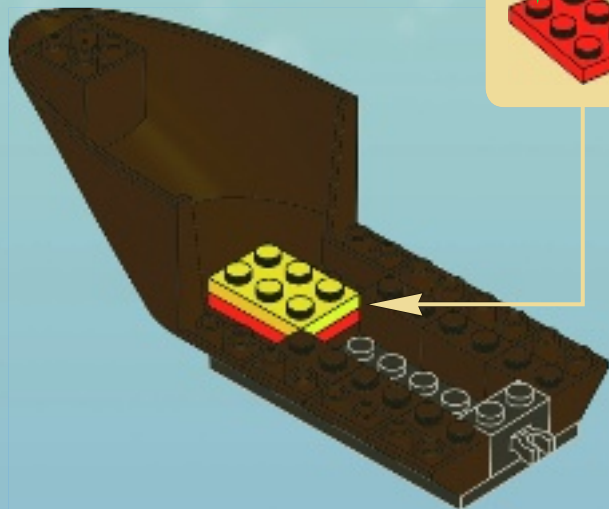

6

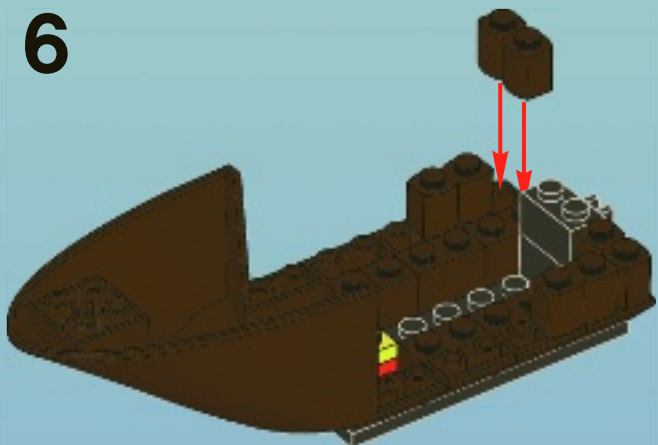

7

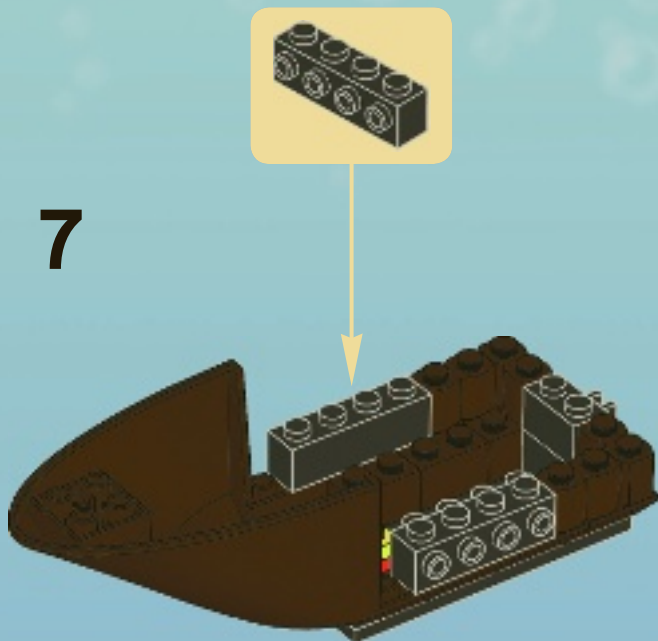

8

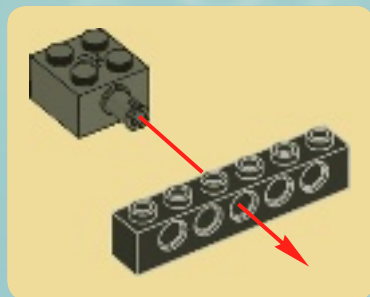
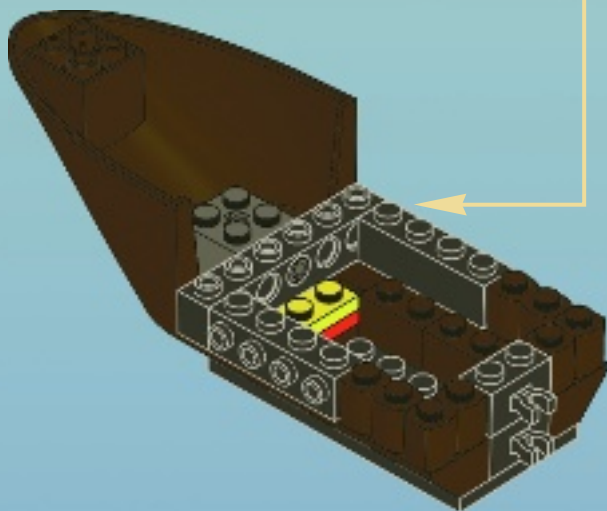

9



10

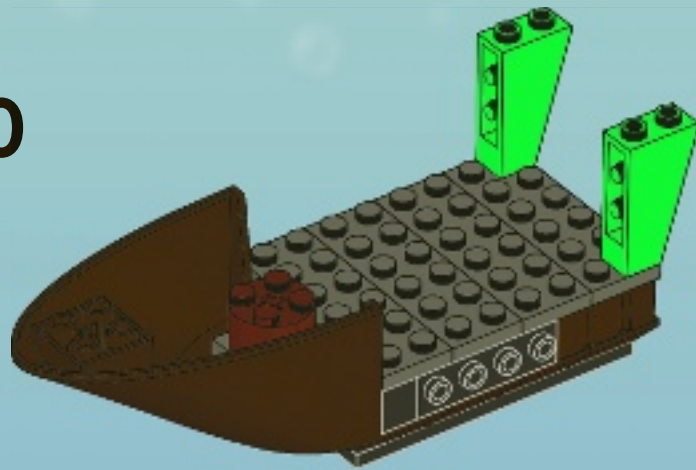



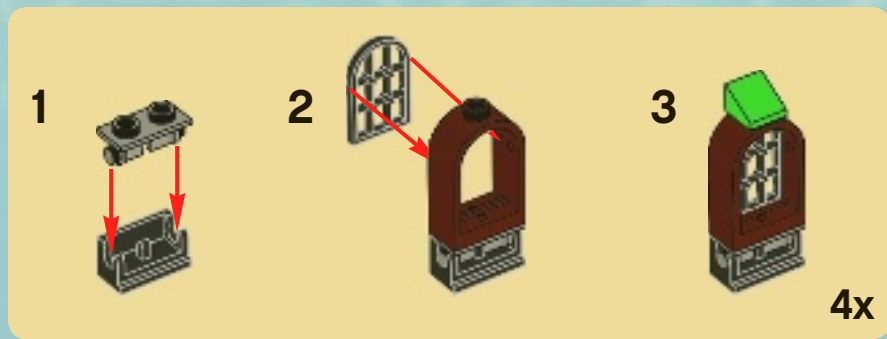

11

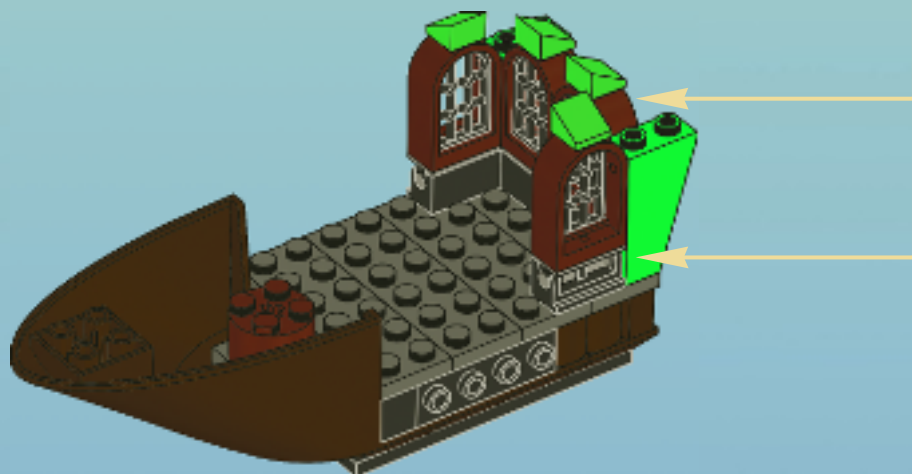

12

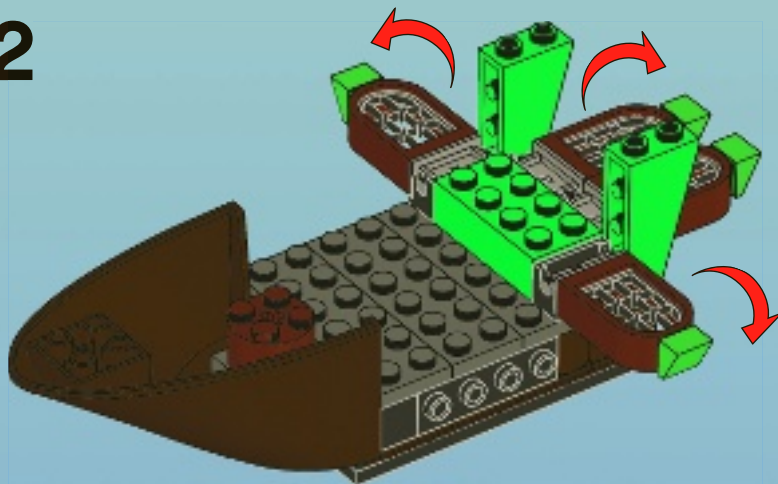

13

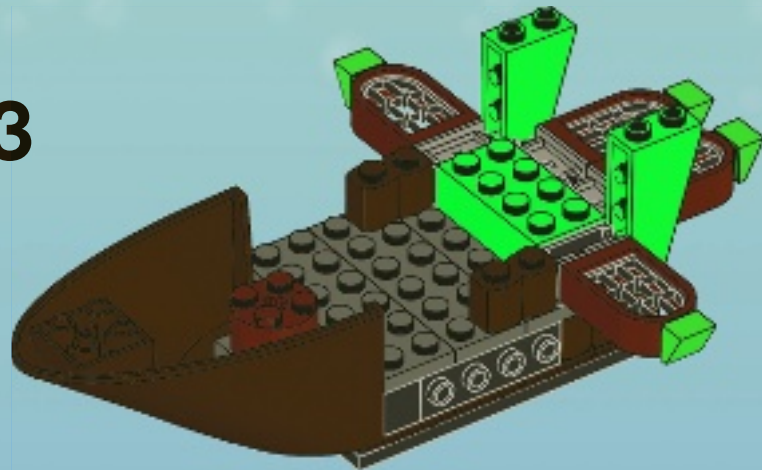

14

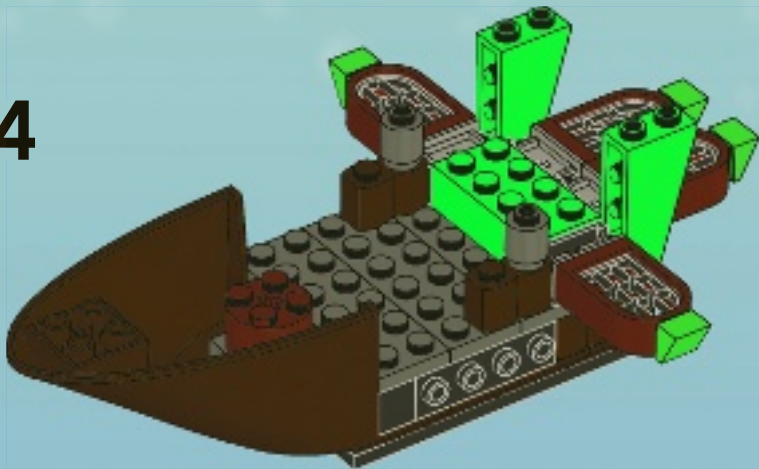

15

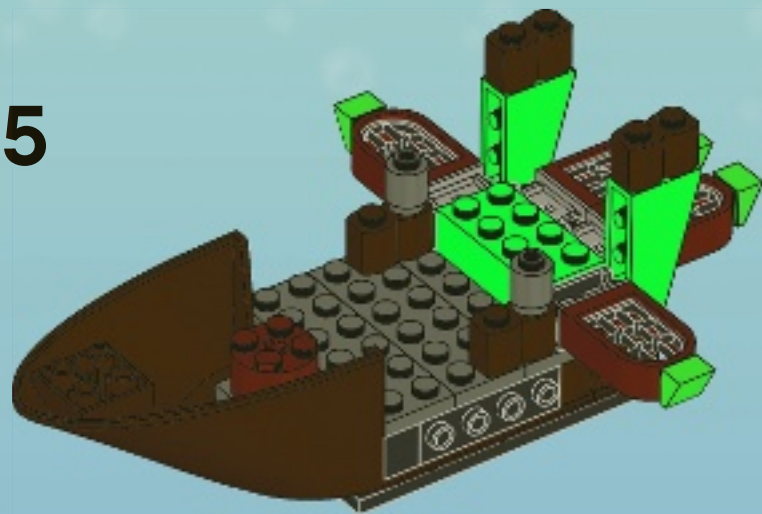

16

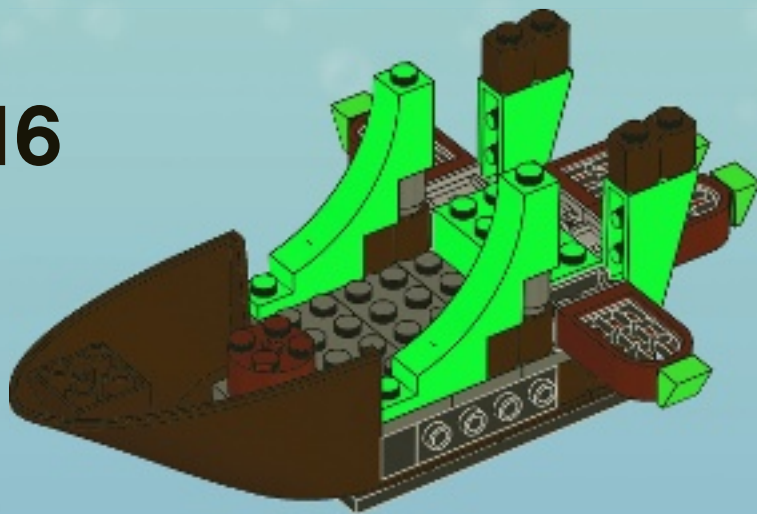

17

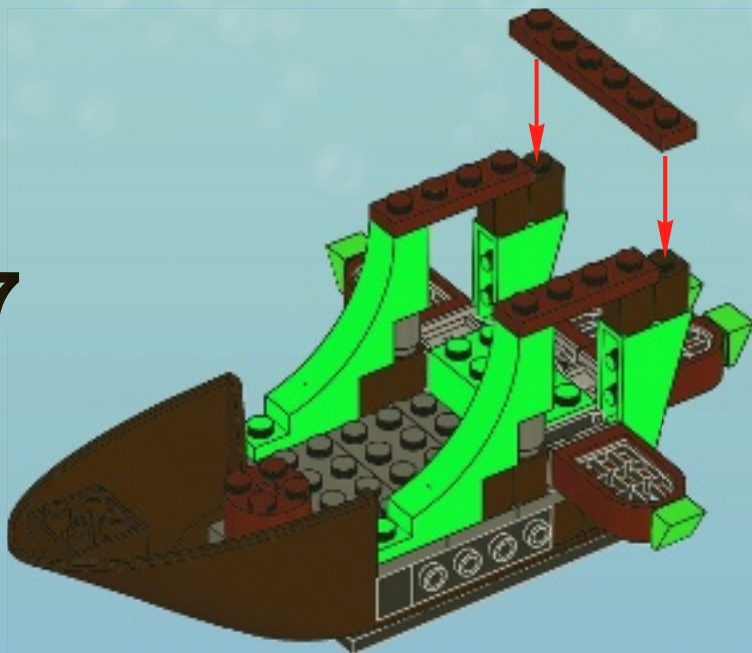

18

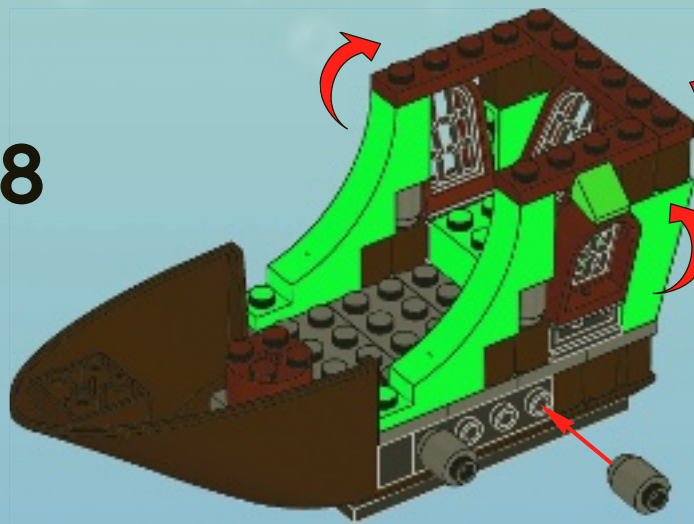



19

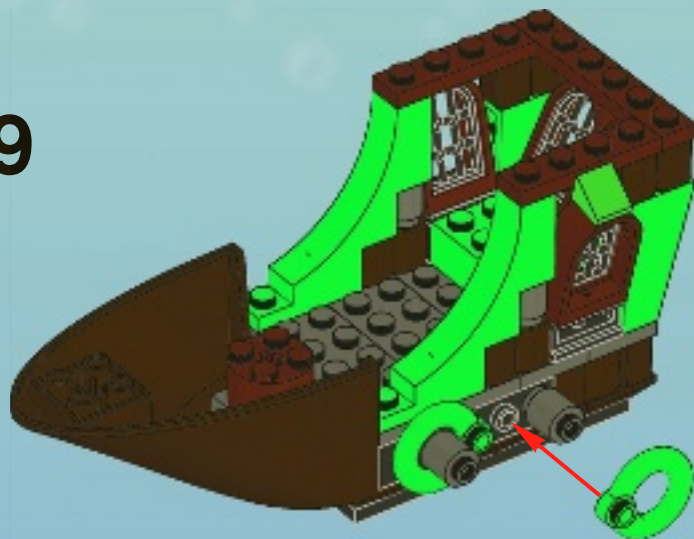



20

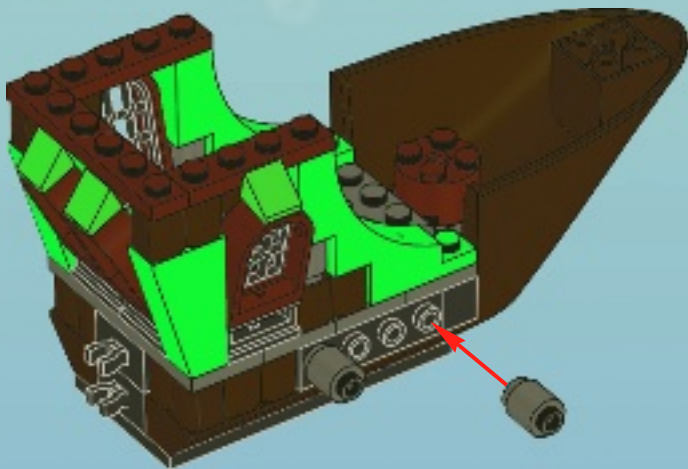

21

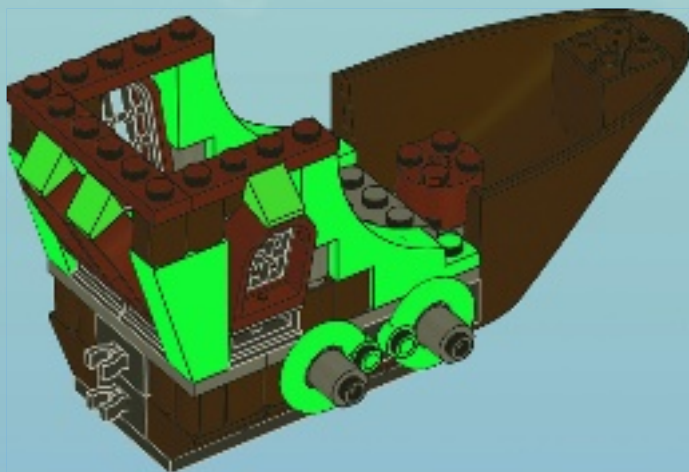



22

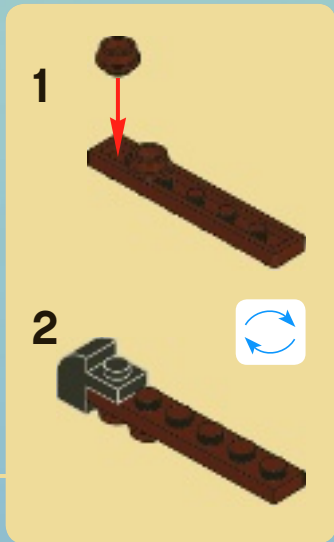
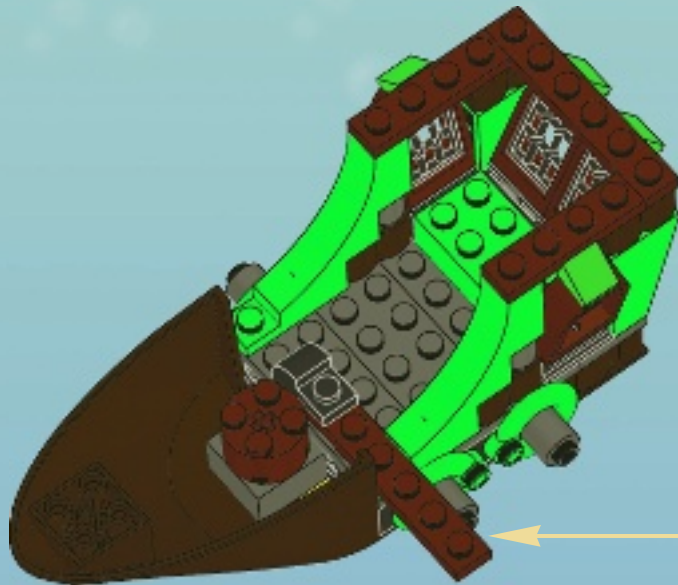

23

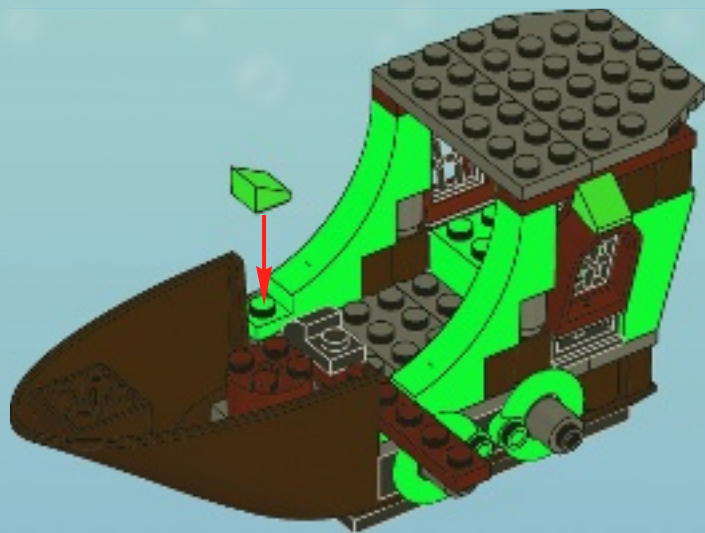



24

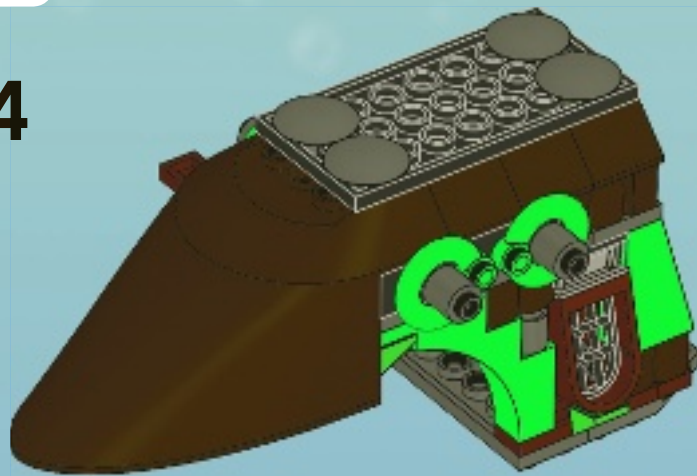



25

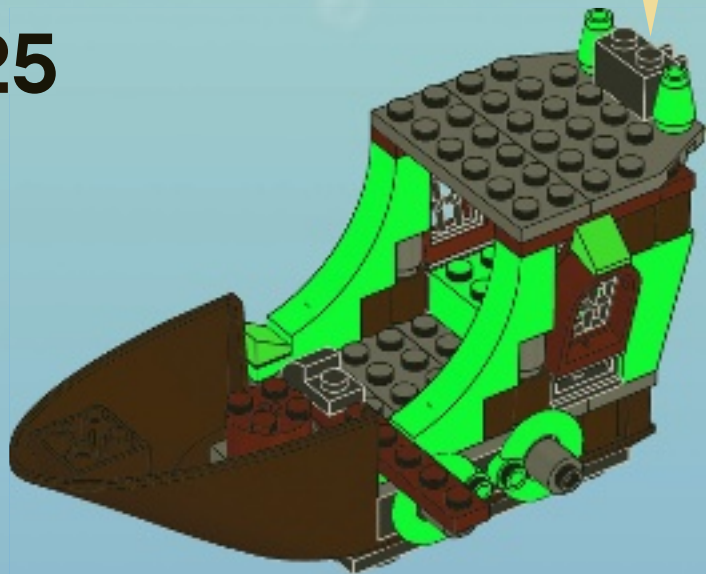

26

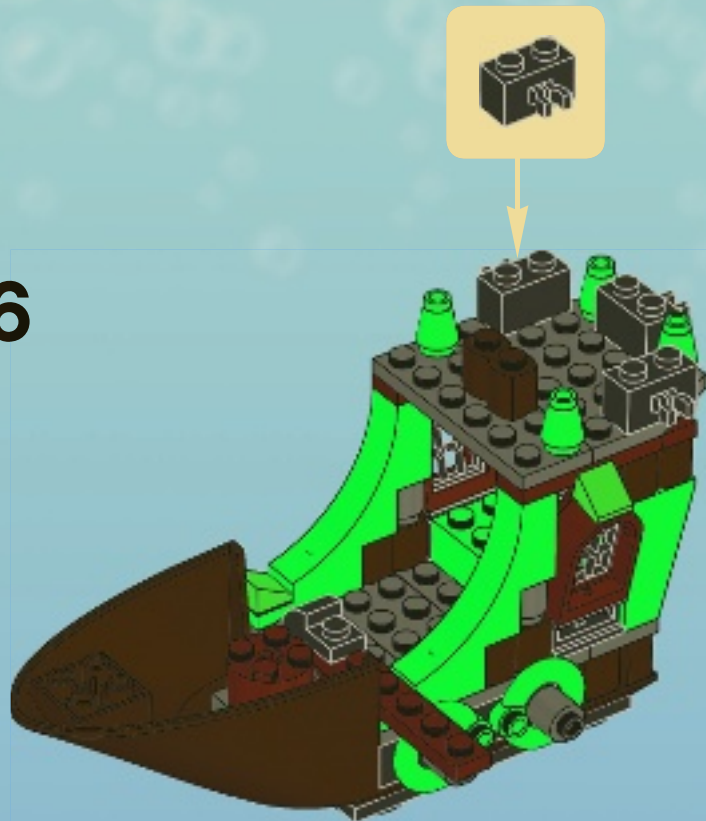



27

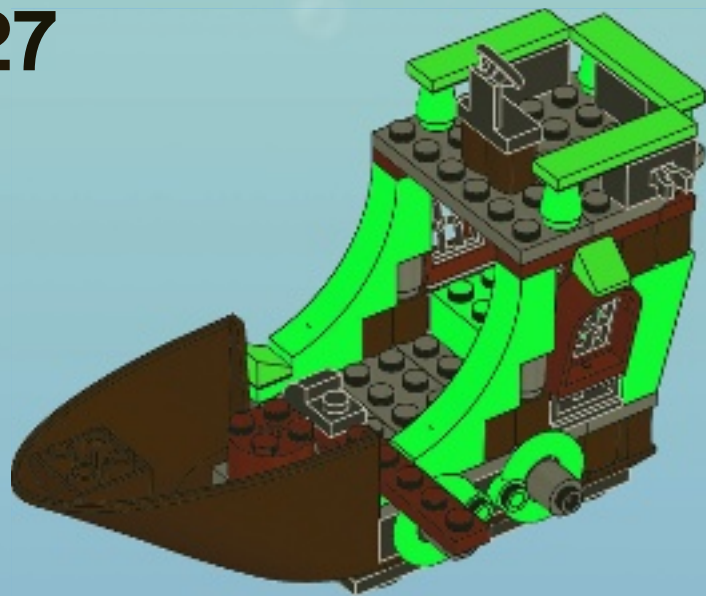

28

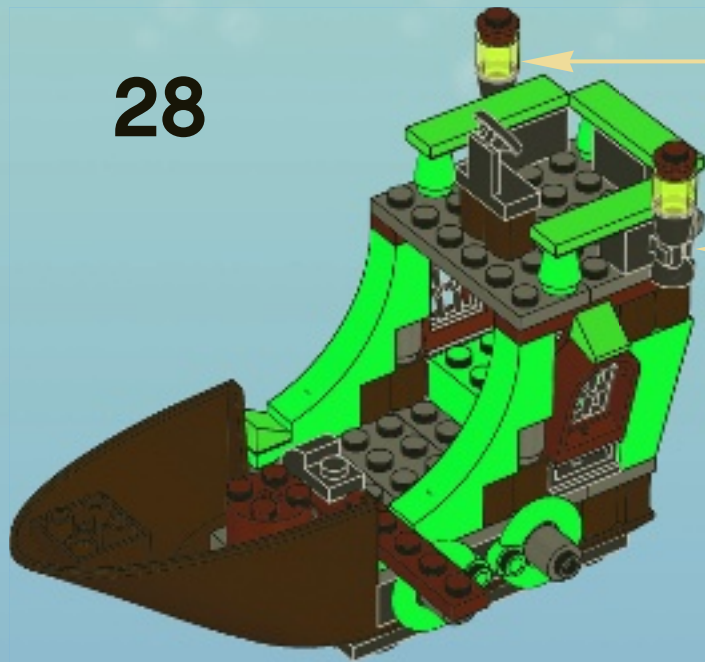

1



2



2x

1



2



3



29

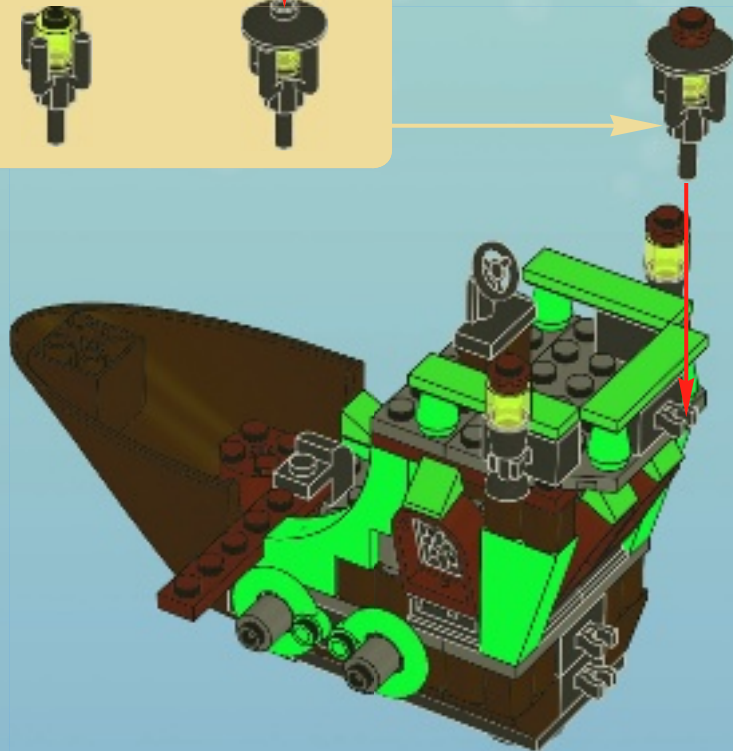

30

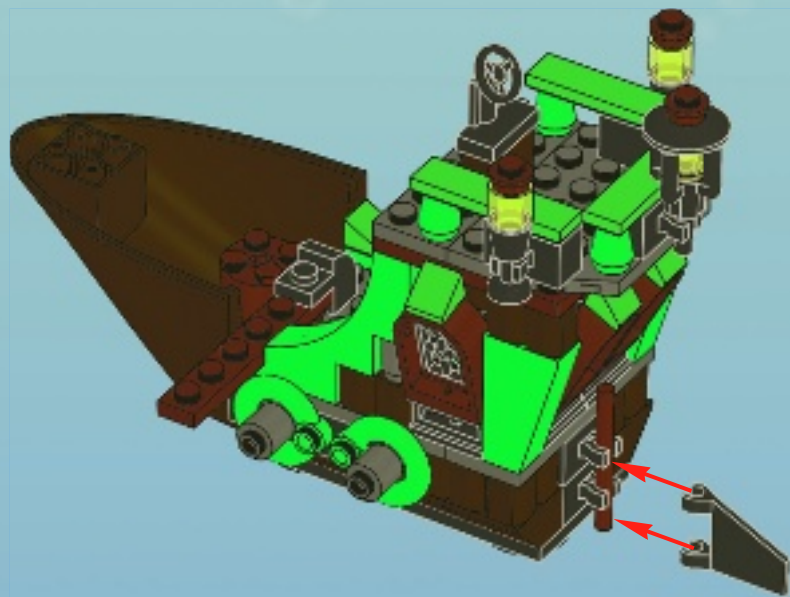



1



2



3

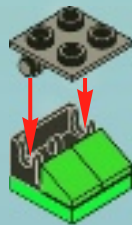

4



5



6

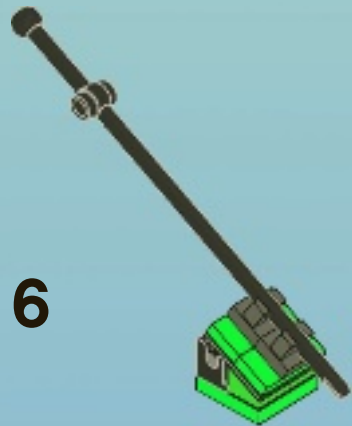

31

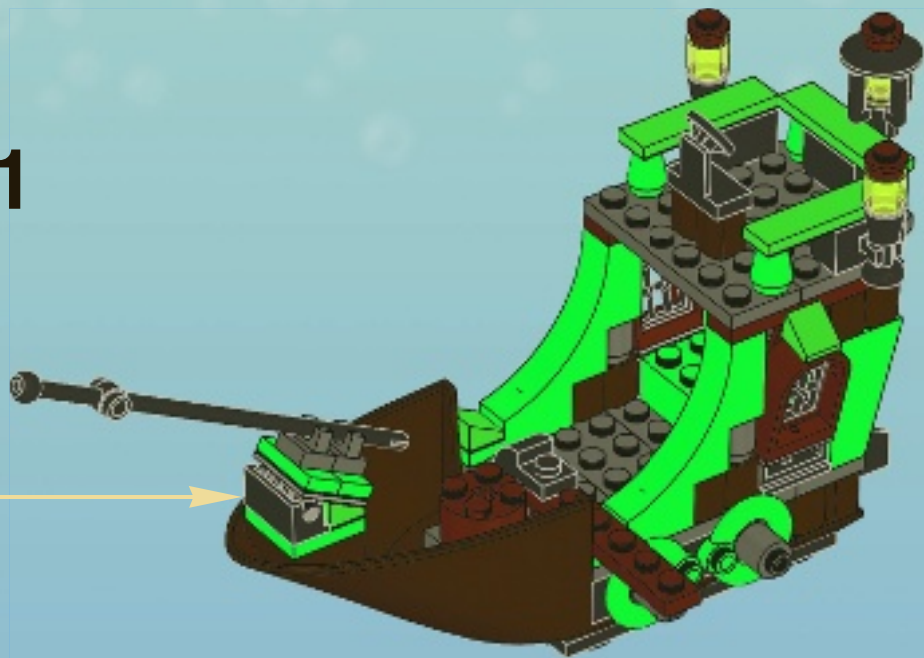



**1**



**2**



**3**





4



5



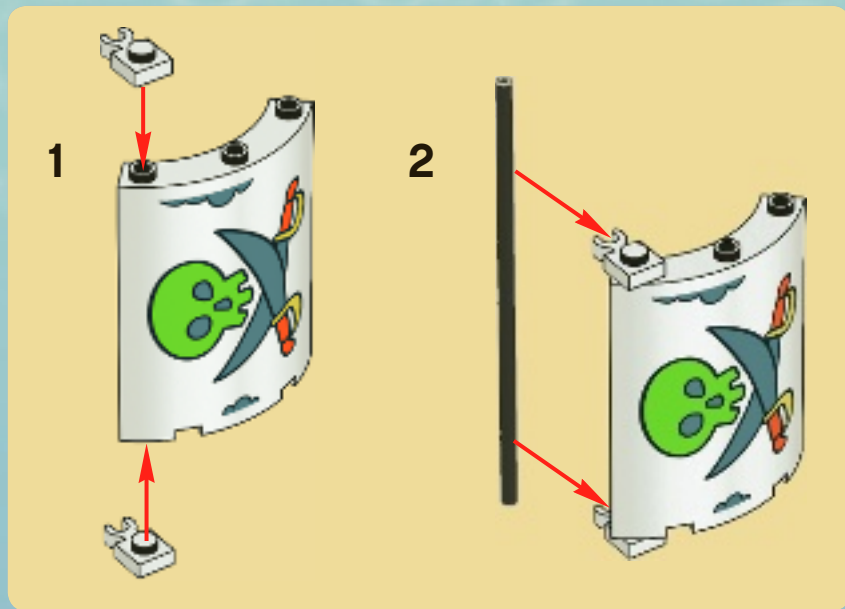

6

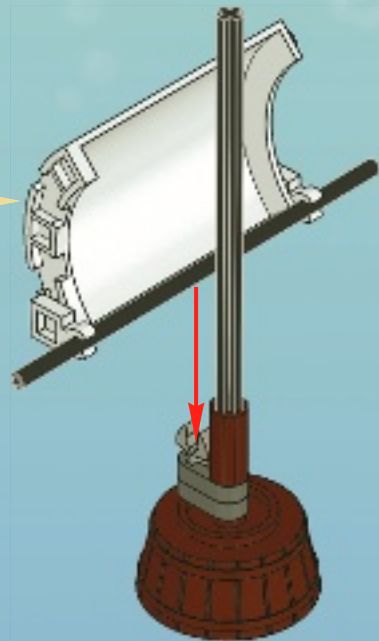

32

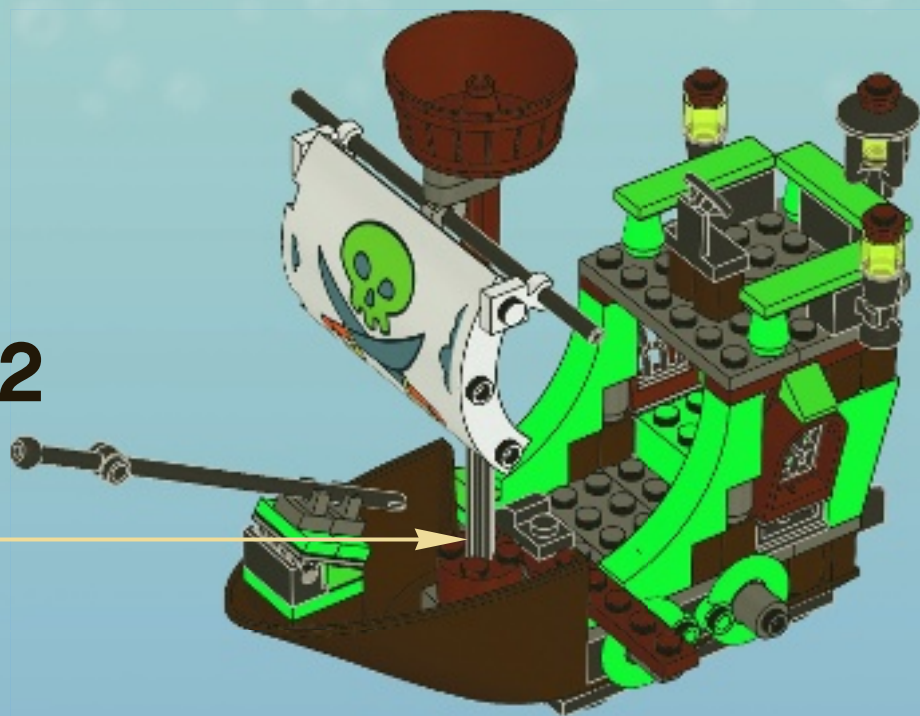

33

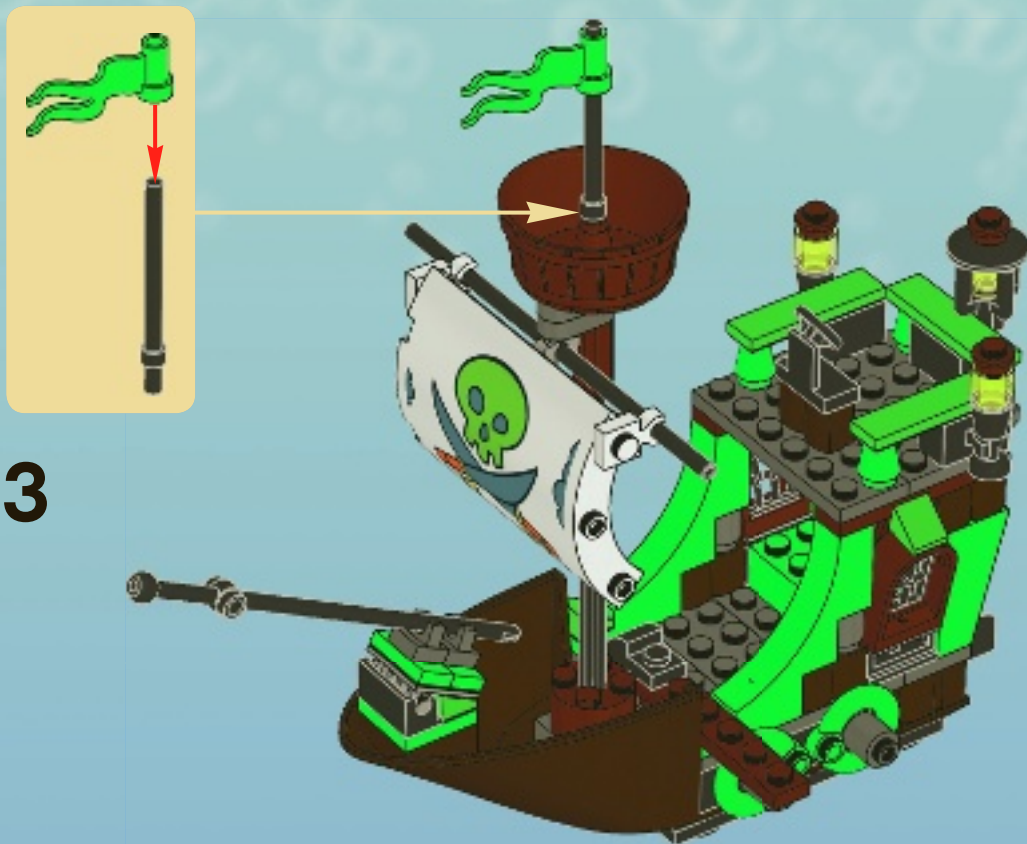

34

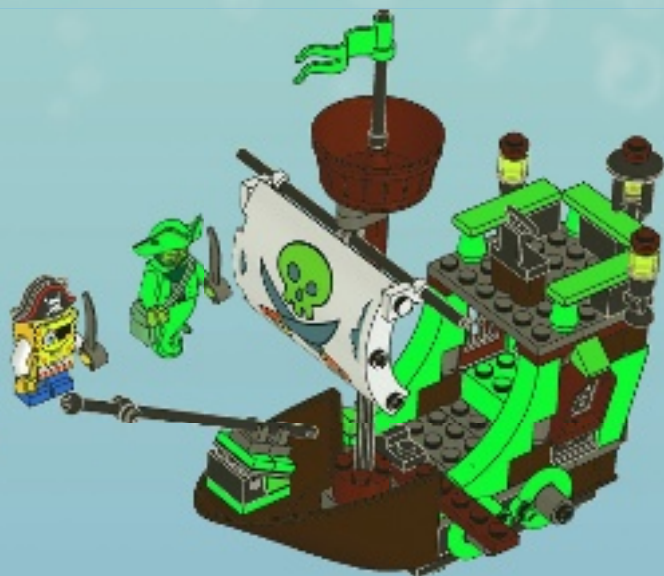
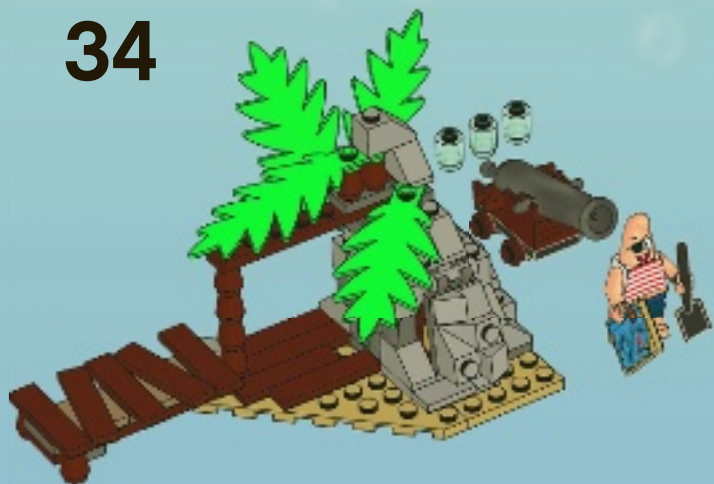





nickelodeon

# SpongeBob SQUAREPANTS™





1x  
4585203



1x  
4140562



1x  
4124460



1x  
4509897



1x  
4626948



1x  
302121



1x  
4543857



1x  
302124



1x  
4654968



1x  
4653143



2x  
4613256



1x  
4655043



3x  
4523159



2x  
4223189



1x  
4658972



1x  
609126



1x  
4538722



1x  
370826

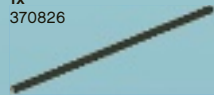

1x  
4296268

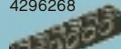

1x  
389426



1x  
303526



2x  
281726



1x  
474026



1x  
4189009



1x  
73081



1x  
4648298



1x  
4532220



5x  
393726



5x  
4118624



2x  
4162443



11x  
4211194



2x  
4211190



2x  
4221590

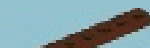

1x  
4216945



1x  
4211211



1x  
4538718



4x  
4542131



1x  
4541875



1x  
4211163



1x  
4533101



13x  
4216581



9x  
4529242



1x  
4211166



1x  
4262974



1x  
4531751



5x  
4521921



10x  
4211614



1x  
4542590



1x  
4211414



1x  
4244627



4x  
4211470



1x  
4211385



3x  
4211095



2x  
4210789



9x  
4519970



1x  
4106356



4x  
4655148



2x  
379428



3x  
4183544



2x  
4211846



1x  
4211046



2x  
4210980



6x  
4648296



2x  
4629678



3x  
4647548



7x  
4647546



3x  
4107106



4x  
4211435



6x  
4211090



1x  
4211043



1x  
4648300



1x  
302228



1x  
4654997



1x  
4655012



2x  
4578032



3x  
4211395



10x  
4211063



5x  
4211002



1x  
4638950



2x  
4653205



1x  
4651926



1x  
4653155



1x  
4653199



1x  
4211881



1x  
4263176

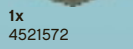

1x  
4521572



1x  
4638950



1x  
449528



4x  
4258459



4x  
4211483



4x  
4278274



1x  
4653124



4x  
4105221



4x  
4529239



1x  
4211815



2x  
4211069



1x  
4654993



1x  
4184617



1x  
4655014

Customer Service

Kundenservice

Service Consommateurs

Servicio Al Consumidor

[www.lego.com/service](http://www.lego.com/service) or dial



: 00800 5346 5555

: 1-800-422-5346







nickelodeon

# SpongeBob SQUAREPANTS



3818



[LEGO.com/spongebob](http://LEGO.com/spongebob)

3815



3816





# WIN!

Go to [www.LEGOsurvey.com/product](http://www.LEGOsurvey.com/product) to fill out a survey for a chance to win a cool LEGO® Product.

No purchase necessary.

Open to all residents where not prohibited.



## [www.LEGOsurvey.com/product](http://www.LEGOsurvey.com/product)

### GEWINNE!

Nimm an der Umfrage auf [www.LEGOsurvey.com/product](http://www.LEGOsurvey.com/product) teil und hab die Chance ein cooles LEGO® Produkt zu gewinnen!

Die Teilnahme am Gewinnspiel führt zu keinerlei Kaufverpflichtungen. Teilnahme in allen nicht ausgeschlossenen Ländern möglich.

### WIN!

Ga naar [www.LEGOsurvey.com/product](http://www.LEGOsurvey.com/product), vul een enquêteformulier in en maak kans op een cool LEGO® product.

Geen aankoopverplichting, iedereen mag deelnemen, uitgezonderd ingezetenden van landen waar een enquêteverbod geldt.

### GAGNE !

Visite [www.LEGOsurvey.com/product](http://www.LEGOsurvey.com/product) pour répondre à un questionnaire et avoir une chance de gagner un produit LEGO® très cool !

Aucune obligation d'achat. Ouvert à tous les résidents des pays autorisés.

### 当てよう!

[www.LEGOsurvey.com/product](http://www.LEGOsurvey.com/product) にアクセスして、アンケートにご記入ください。当選者にはレゴ®製品を差し上げます。

お買い上げの必要はありません。禁止されていない限り、すべての皆様にご利用いただけます。

LEGO and the LEGO logo are trademarks of the/son/des marques de commerce de/son marcas registradas de LEGO Group. ©2012 The LEGO Group. © 2012 Viacom International Inc. All Rights Reserved. Nickelodeon, SpongeBob SquarePants and all related titles, logos and characters are trademarks of Viacom International Inc. SpongeBob SquarePants created by Stephen Hillenburg. © 2012 Viacom International Inc. Toute reproduction interdite, Nickelodeon, Bob L'éponge ainsi que les logos, les personnages et les autres titres qui s'y rapportent sont des marques de commerce de Viacom International Inc. Bob L'éponge créé par Stephen Hillenburg.

© 2012 Viacom International Inc. Todos los derechos reservados. Nickelodeon, Bob Esponja y todos los títulos, logotipos y personajes del mismo género son marcas de Viacom International Inc. Bob Esponja creado por Stephen Hillenburg.

[www.nick.com](http://www.nick.com) [www.nickelodeon.tv](http://www.nickelodeon.tv)



[www.LEGO.com](http://www.LEGO.com)

6003868